

L:
 CBL-302C-3m 3000mm±20mm
 CBL-302C-5m 5000mm±50mm
 CBL-302C-7m 7000mm±50mm

No	MATERIALS LIST:
1.	CABLE:UL2725 (28AWG*1PR+D+AM)x2C+28AWG*1PR+24AWG*1C+AM+B OD:5.6mm PVC JACKET COLOR:BLACK
2.	CONNECTOR:USB 3.0 A/M, 9P, BLUE INSULATOR SOLDER TYPE, NICKEL PLATED SHELL
3.	CONNECTOR:USB 3.0 A/F, 9P, BLUE INSULATOR SOLDER TYPE, NICKEL PLATED SHELL
4.	ABS ASSEMBLY HOUSING, BLACK COLOR

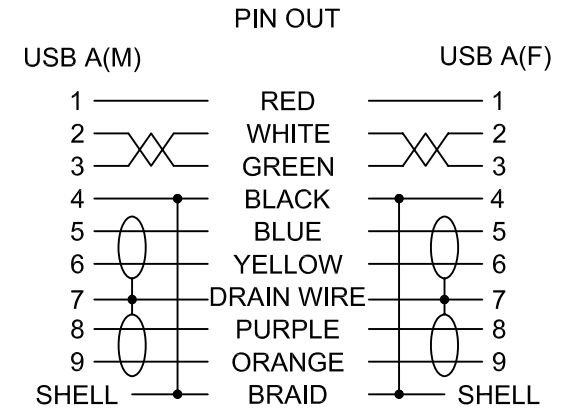

Jargy part no.	Client part no.	Approved	SCALE	UNIT
CBL-302C-Xm			1 : 1	mm
Drawing Name		Drawn	Date	REV.
USB 3.0 A to A Extension Cables M/F		<i>Kevin Hsu</i>	2015/09/09	1.0

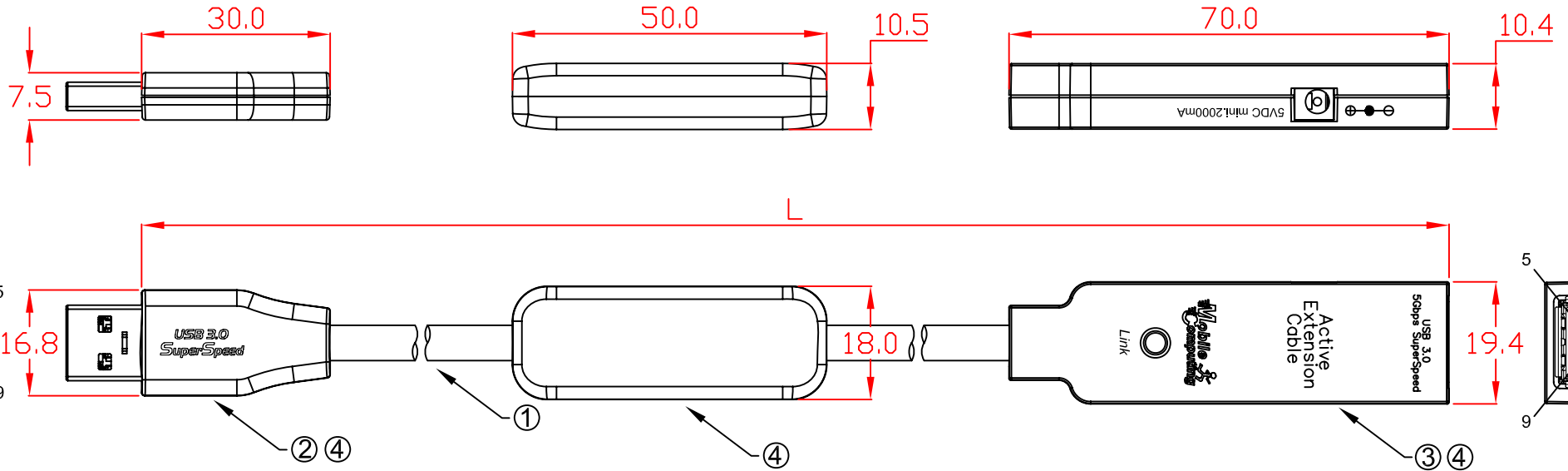

L:
 CBL-302C-10m 10000mm±50mm
 CBL-302C-15m 15000mm±50mm

No	MATERIALS LIST:
1.	CABLE:UL2725 (28AWG*1PR+D+AM)x2C+28AWG*1PR+24AWG*1C+AM+B OD:5.6mm PVC JACKET COLOR:BLACK
2.	CONNECTOR:USB 3.0 A/M, 9P, BLUE INSULATOR SOLDER TYPE, NICKEL PLATED SHELL
3.	CONNECTOR:USB 3.0 A/F, 9P, BLUE INSULATOR SOLDER TYPE, NICKEL PLATED SHELL
4.	ABS ASSEMBLY HOUSING, BLACK COLOR

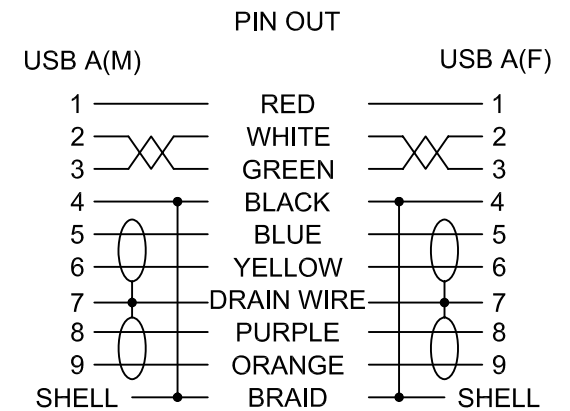

Jargy part no.	Client part no.	Approved	SCALE	UNIT
CBL-302C-Xm			1 : 1	mm
Drawing Name		Drawn	Date	REV.
USB 3.0 A to A Extension Cables M/F		<i>Kevin Hsu</i>	2015/09/09	1.0

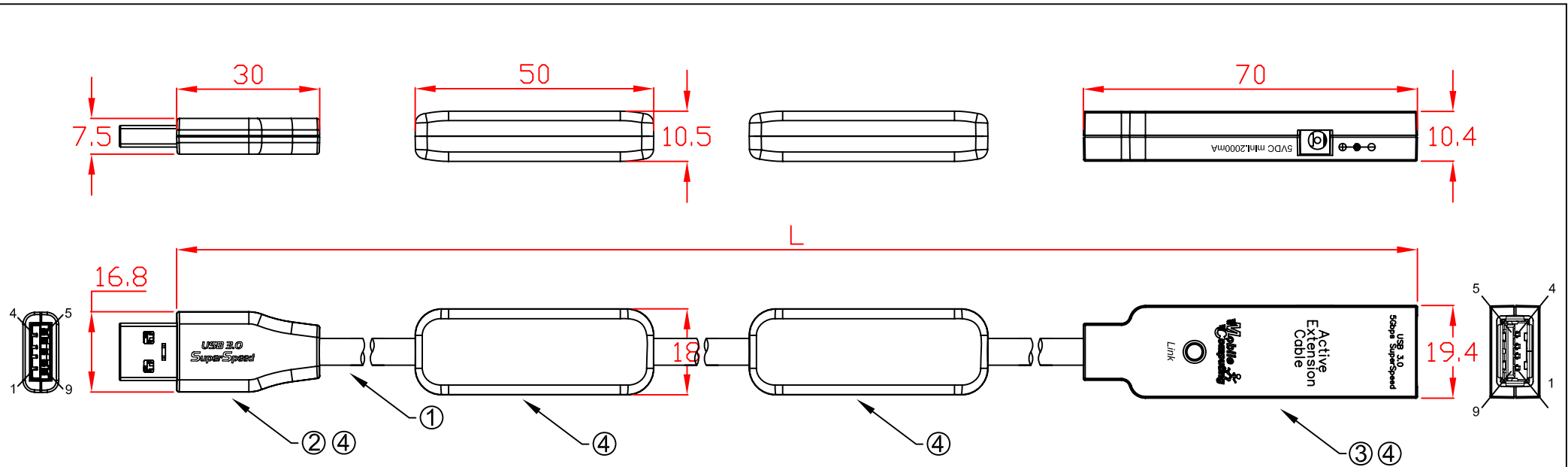

L:
CBL-302C-20m 20000mm±50mm

No	MATERIALS LIST:
1.	CABLE:UL2725 (28AWG*1PR+D+AM)x2C+28AWG*1PR+24AWG*1C+AM+B OD:5.6mm PVC JACKET COLOR:BLACK
2.	CONNECTOR:USB 3.0 A/M, 9P, BLUE INSULATOR SOLDER TYPE, NICKEL PLATED SHELL
3.	CONNECTOR:USB 3.0 A/F, 9P, BLUE INSULATOR SOLDER TYPE, NICKEL PLATED SHELL
4.	ABS ASSEMBLY HOUSING, BLACK COLOR

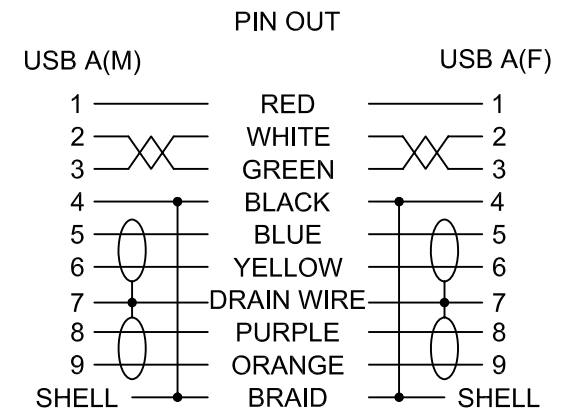

Jargy part no.	Client part no.	Approved	SCALE	UNIT
CBL-302C-20m			1 : 2	mm
Drawing Name		Drawn	Date	REV.
USB 3.0 A to A Extension Cables M/F		<i>Kevin Hsu</i>	2015/09/09	1.0

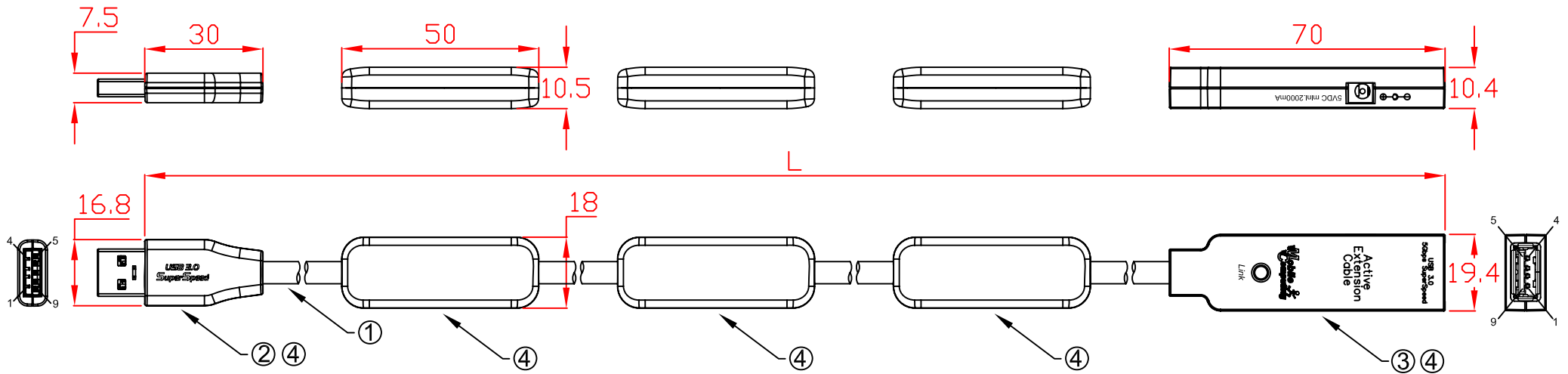

L:
CBL-302C-25m 25000mm±50mm

No	MATERIALS LIST:
1.	CABLE:UL2725 (28AWG*1PR+D+AM)x2C+28AWG*1PR+24AWG*1C+AM+B OD:5.6mm PVC JACKET COLOR:BLACK
2.	CONNECTOR:USB 3.0 A/M, 9P, BLUE INSULATOR SOLDER TYPE, NICKEL PLATED SHELL
3.	CONNECTOR:USB 3.0 A/F, 9P, BLUE INSULATOR SOLDER TYPE, NICKEL PLATED SHELL
4.	ABS ASSEMBLY HOUSING, BLACK COLOR

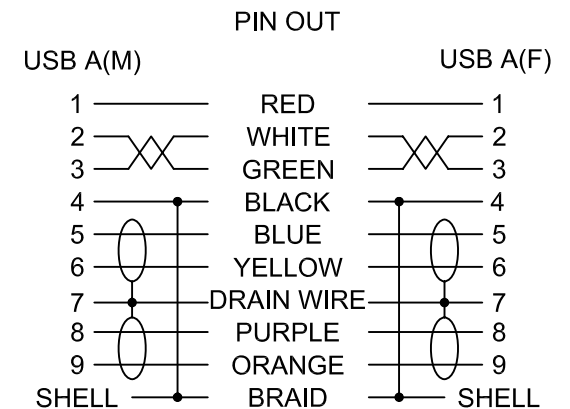

Jargy part no.	Client part no.	Approved	SCALE	UNIT
CBL-302C-25m			1 : 2	mm
Drawing Name		Drawn	Date	REV.
USB 3.0 A to A Extension Cables M/F		<i>Kevin Hsu</i>	2015/09/09	1.0

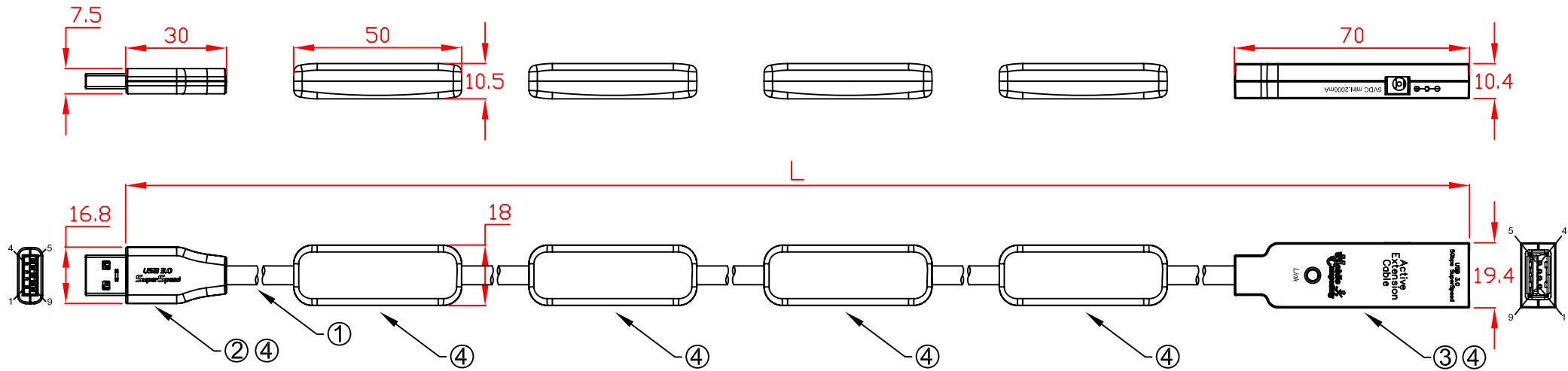

L:
CBL-302C-30m 30000mm±50mm

No	MATERIALS LIST:
1.	CABLE:UL2725 (28AWG*1PR+D+AM)x2C+28AWG*1PR+24AWG*1C+AM+B OD:5.6mm PVC JACKET COLOR:BLACK
2.	CONNECTOR:USB 3.0 A/M, 9P, BLUE INSULATOR SOLDER TYPE, NICKEL PLATED SHELL
3.	CONNECTOR:USB 3.0 A/F, 9P, BLUE INSULATOR SOLDER TYPE, NICKEL PLATED SHELL
4.	ABS ASSEMBLY HOUSING, BLACK COLOR

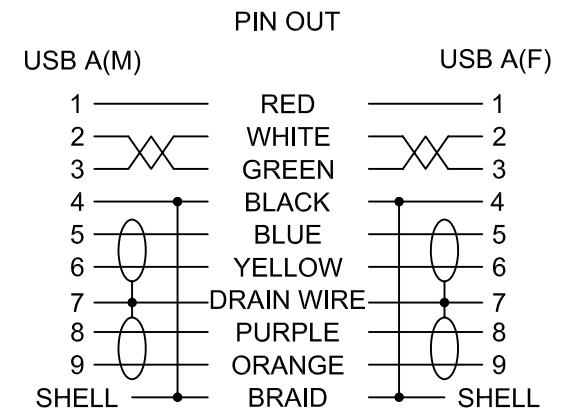

Jargy part no.	Client part no.	Approved	SCALE	UNIT
CBL-302C-30m			1 : 2	mm
Drawing Name		Drawn	Date	REV.
USB 3.0 A to A Extension Cables M/F		<i>Kevin Hsu</i>	2015/09/09	1.0

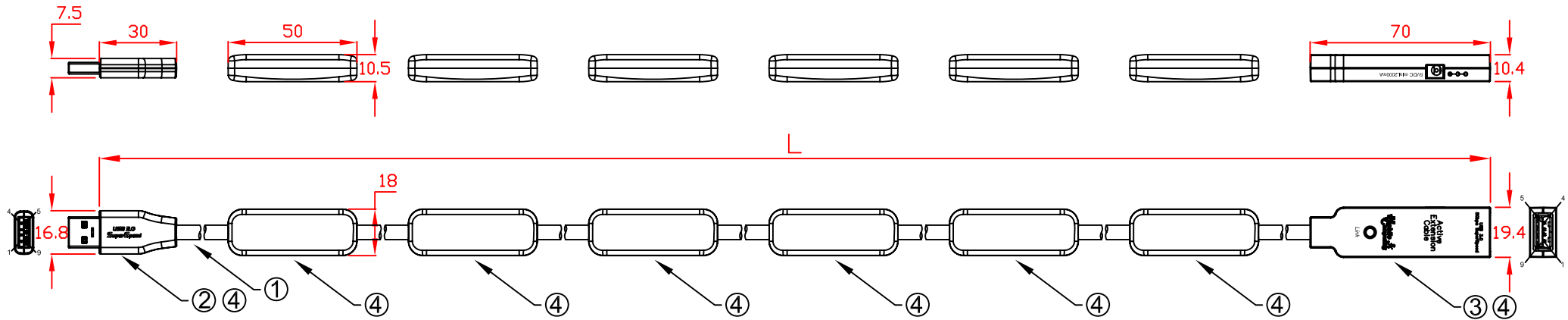

L:
CBL-302C-35m 35000mm±50mm

No	MATERIALS LIST:
1.	CABLE:UL2725 (28AWG*1PR+D+AM)x2C+28AWG*1PR+24AWG*1C+AM+B OD:5.6mm PVC JACKET COLOR:BLACK
2.	CONNECTOR:USB 3.0 A/M, 9P, BLUE INSULATOR SOLDER TYPE, NICKEL PLATED SHELL
3.	CONNECTOR:USB 3.0 A/F, 9P, BLUE INSULATOR SOLDER TYPE, NICKEL PLATED SHELL
4.	ABS ASSEMBLY HOUSING, BLACK COLOR

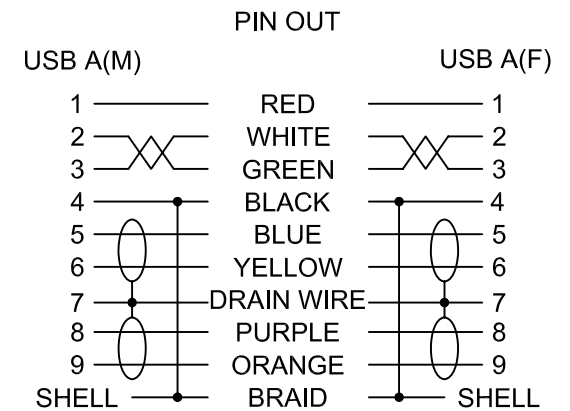

Jargy part no.	Client part no.	Approved	SCALE	UNIT
CBL-302C-35m			1 : 2	mm
Drawing Name		Drawn	Date	REV.
USB 3.0 A to A Extension Cables M/F		<i>Kevin Hsu</i>	2015/09/09	1.0

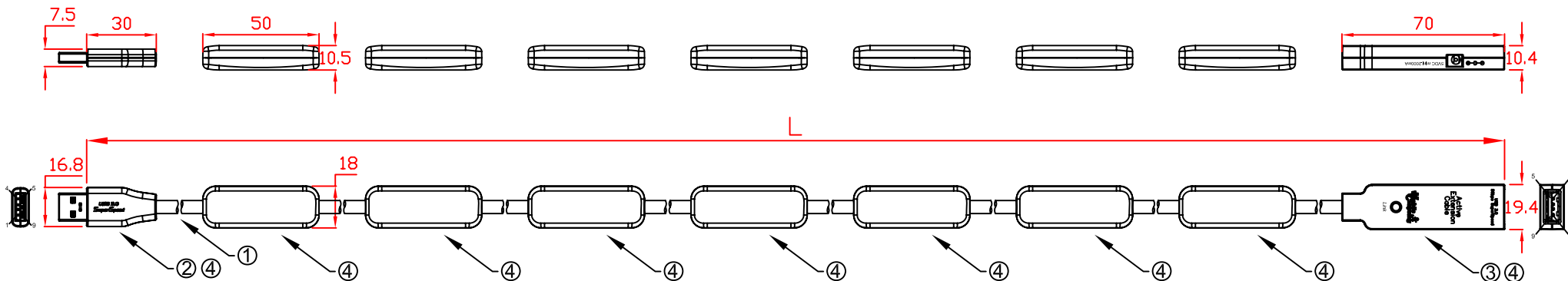

L:
CBL-302C-40m 40000mm±50mm

No	MATERIALS LIST:
1.	CABLE:UL2725 (28AWG*1PR+D+AM)x2C+28AWG*1PR+24AWG*1C+AM+B OD:5.6mm PVC JACKET COLOR:BLACK
2.	CONNECTOR:USB 3.0 A/M, 9P, BLUE INSULATOR SOLDER TYPE, NICKEL PLATED SHELL
3.	CONNECTOR:USB 3.0 A/F, 9P, BLUE INSULATOR SOLDER TYPE, NICKEL PLATED SHELL
4.	ABS ASSEMBLY HOUSING, BLACK COLOR

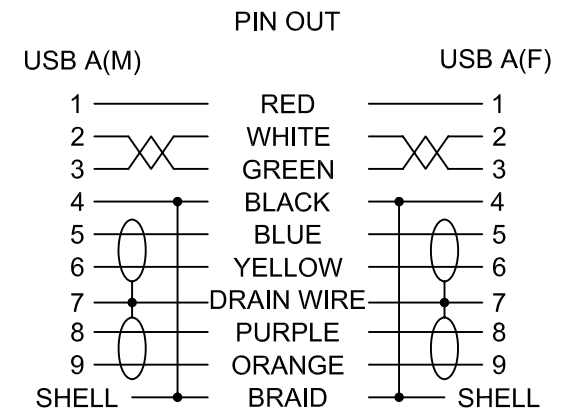

Jargy part no.	Client part no.	Approved	SCALE	UNIT
CBL-302C-40m			1 : 2	mm
Drawing Name		Drawn	Date	REV.
USB 3.0 A to A Extension Cables M/F		<i>Kevin Hsu</i>	2015/09/21	1.0



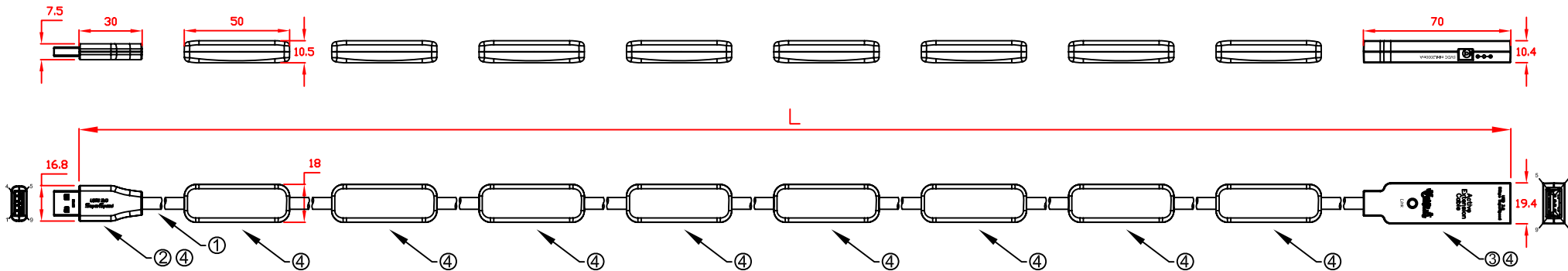

L:
 CBL-302C-45m 45000mm±50mm
 CBL-302C-50m 50000mm±50mm

No	MATERIALS LIST:
1.	CABLE:UL2725 (28AWG*1PR+D+AM)x2C+28AWG*1PR+24AWG*1C+AM+B OD:5.6mm PVC JACKET COLOR:BLACK
2.	CONNECTOR:USB 3.0 A/M, 9P, BLUE INSULATOR SOLDER TYPE, NICKEL PLATED SHELL
3.	CONNECTOR:USB 3.0 A/F, 9P, BLUE INSULATOR SOLDER TYPE, NICKEL PLATED SHELL
4.	ABS ASSEMBLY HOUSING, BLACK COLOR

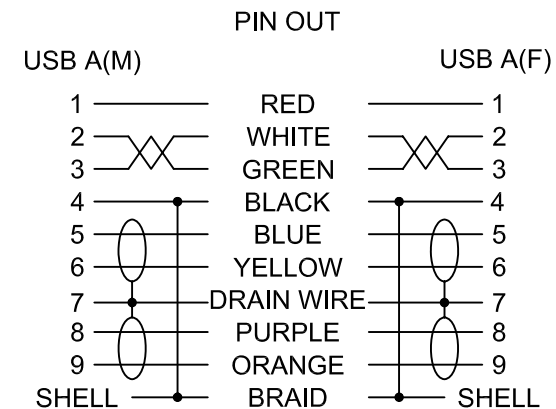

Jargy part no.	Client part no.	Approved	SCALE	UNIT
CBL-302C-Xm			1 : 2	mm
Drawing Name		Drawn	Date	REV.
USB 3.0 A to A Extension Cables M/F		<i>Kevin Hsu</i>	2015/09/21	1.0